

DPC.micro

compact programmable effects switcher



user manual



INTRODUCTION

Thank you for your interest in the DPC.micro Programmable Effects Switcher.

The DPC.micro packs three true-bypass effects loops into a small footprint, adding in MIDI control and preset capability for good measure. Each loop may be individually controlled using the footswitches on the DPC.micro or by MIDI remote control. You can also save your favorite effects loop settings to preset combinations for later recall.

INS AND OUTS

Most of the connections to the DPC.micro are located on the rear panel of the device as shown below.

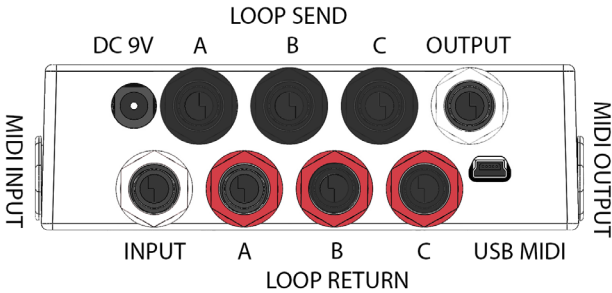

The white jacks on the rear panel serve as input and output connections. Plug your instrument into the white jack nearest to the power jack, and plug your amplifier into the white jack next to the USB port.

The remaining jacks connect to your pedals. The black jacks are the effects sends, which should connect to the input of each pedal. The red jacks are the returns, and connect to the output of each pedal.

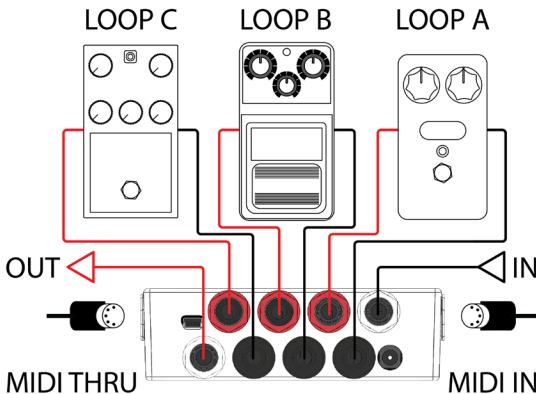

Connect your pedals as shown in the diagram above. Make sure to **engage** all of your pedals in the loops! The DPC.micro can bypass and engage them remotely only if the pedals are powered on and engaged.

The bypass state of each loop will be shown on the DPC.micro, but the LEDs on the looped pedals themselves will not change.

CONTROLLING YOUR PEDALS

This part is pretty simple! Tap the footswitches labeled A, B, and C to change the status of the A, B, and C loops. That's pretty much it - three loops, no waiting.

LOOP MODE

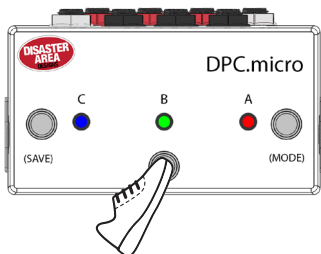

Tap the footswitches to engage or bypass each loop.

The loop state is indicated by the LED next to each footswitch.

Hold the C (SAVE) footswitch to save the current loop settings to the last active preset.

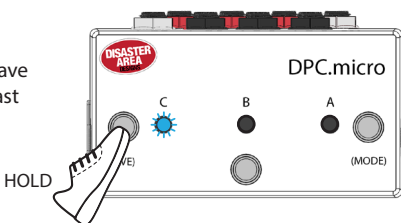

Hold the A (MODE) footswitch to switch between LOOP and PRESET modes.

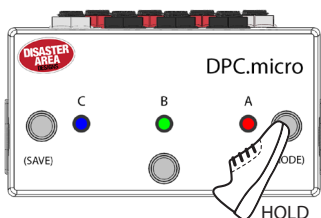

PRESET MODE

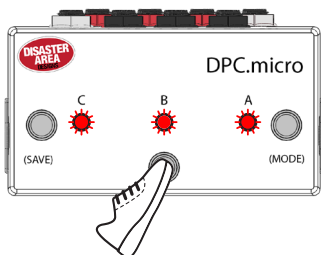

Tap the footswitches to select a preset. ALL LEDs will flash red, then the current preset will light in WHITE.

Tap the current preset to load preset zero (bypass or favorite.)

If you're using the DPC.micro with a MIDI controller, we recommend you keep it in Loop Mode. This will allow you to see the current loop states, as well as override the loop controls if desired.

CONFIGURATION

The DPC.micro has two configuration modes: MIDI and Display. To enter a configuration mode, power on the DPC.micro and then hold the relevant button after the LEDs start flashing.

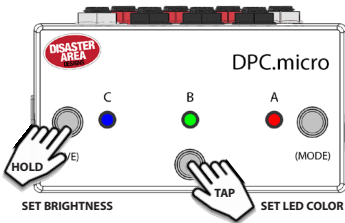

DISPLAY CONFIGURATION - HOLD B.

Tap each footswitch to set the LED color used in LOOP MODE.

Hold any footswitch to set the LED Brightness.

Power off to save.

MIDI CONFIGURATION - HOLD C.

Tap footswitch A to set the MIDI Chain ID.

RED = 0, GREEN = 1, BLUE = 2, ORANGE = 3.

Tap footswitch B to set the automatic pop reduction.

OFF = disable, RED = low, GREEN = medium, BLUE = high.

Send a MIDI program change message from your controller to set the DPC MIDI channel.

Power off to save.

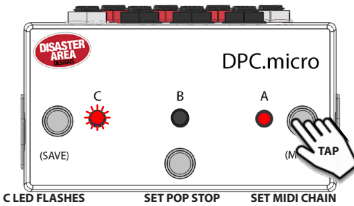

FACTORY RESET: Hold both the A and C buttons at power on to clear all preset data and configuration. The factory default settings are MIDI channel 16, Chain ID 0, Pop reduction OFF, RED / GREEN / BLUE LEDs, Brightness 4.

MIDI CONTROL

There are three ways to control the DPC.micro using MIDI.

The simplest way is to send a program change ranging from 120 to 127. Each program change corresponds to a different unique loop setting, and will never change.

120: No loops active	124: C active
121: A active	125: A & C active
122: B active	126: B & C active
123: A & B active	127: A & B & C active

You can also save your own loop combinations to the internal memory of the DPC.micro, and load them using MIDI program changes 0-119.

Send a MIDI program change from your controller on the DPC.micro's MIDI channel. The DPC will load the contents of its memory. To edit, use the Loop mode on the DPC.micro to change the loop assignments and then hold the C (SAVE) footswitch. The DPC.micro will save the new data in the current memory location.

The final way to control the DPC.micro is to send MIDI CC messages. MIDI CC 50, 51, and 52 control the A, B, and C loops respectively. Send a value from 0-63 to turn the loop OFF, or a value from 64-127 to turn the loop ON.

If more than one DPC.micro is used in the same system, you can use the **MIDI Chain ID** function in the DPC setup to move the range of the MIDI CC values. This allows up to four DPC.micro to share the same MIDI channel and still have each loop be individually accessible from your MIDI controller.

Chain ID	0 (RED)	1 (GRN)	2 (BLU)	3 (ORG)
Loop A CC	50	53	56	59
Loop B CC	51	54	57	60
Loop C CC	52	55	58	61